

# TB 11-5820-890-20-102

---

## TECHNICAL BULLETIN

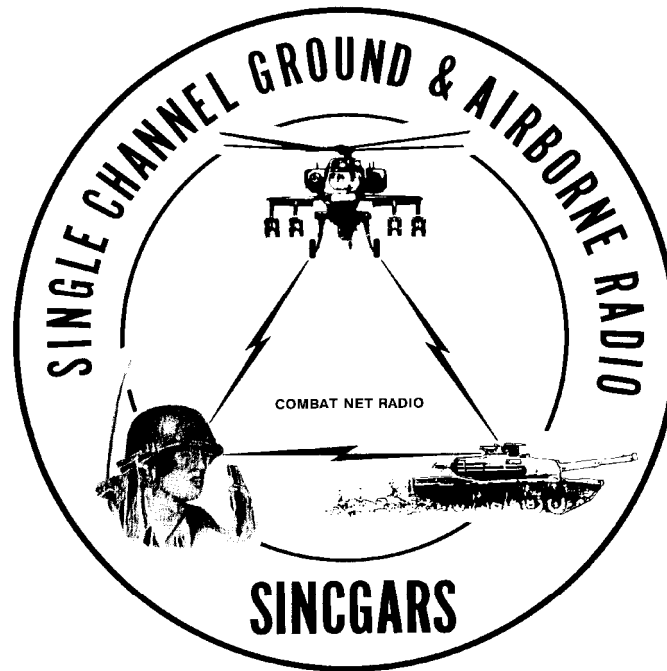

**INSTALLATION INSTRUCTIONS FOR  
INSTALLATION KIT,  
ELECTRONIC EQUIPMENT, MK-2845/VRC  
(NSN 5895-01-441-1334) (EIC: N/A)  
TO PERMIT INSTALLATION OF RADIO SET  
AN/VRC-87/88/90 SERIES  
IN A  
M56 SMOKE GENERATOR**

Approved for public release; distribution is unlimited.

---

**HEADQUARTERS, DEPARTMENT OF THE ARMY**

**1 JULY 2000**

**INSTALLATION INSTRUCTIONS FOR  
INSTALLATION KIT  
ELECTRONIC EQUIPMENT MK-2845/VRC  
(NSN 5895-01-441-1334) (EIC: N/A)  
TO PERMIT INSTALLATION OF RADIO SETS  
AN/VRC-87/88/90 SERIES  
IN A  
M56 SMOKE GENERATOR**

REPORTING OF ERRORS AND RECOMMENDING IMPROVEMENTS

You can help improve this manual. If you find any mistakes or if you know of a way to improve the procedures, please let us know. Mail your letter, DA Form 2028 (Recommended Changes to Publications and Blank Forms), or DA Form 2028-2 located in the back of this manual direct to: Commander, US Army Communications-Electronics Command Fort Monmouth, ATTN: AMSEL-LC-LEO-D-CS-CFO, Fort Monmouth, NJ 07703-5000. The Fax number is 732-532-1413, DSN 992-1413. You may also e-mail your recommendation to [AMSEL-LC-LEO-PUBS-CHG@cecom3.monmouth.army.mil](mailto:AMSEL-LC-LEO-PUBS-CHG@cecom3.monmouth.army.mil).

In either case, a reply will be furnished direct to you.

TABLE OF CONTENTS

Subject	Section	Page
Scope .....	0.1	1
General Information .....	0.2	1
Maintenance Forms, Records, and Reports .....	0.3	1
Reports of Maintenance and Unsatisfactory Equipment .....	0.3.1	1
Report of Packing and Handling Deficiencies .....	0.3.2	1
Discrepancy in Transportation Deficiency Report (TDR) (SF 361) .....	0.3.3	1
Consolidated Index of Army Publications .....	0.4	1
Purpose of Installation .....	1.	2
End Item or System to be Modified .....	2.	2
Application Times .....	3.	2
Time for Completion of Installation .....	3.1	2
Time for Installation of One Assembly or Component .....	3.2	2
Preparation for Installation .....	4.	2
Preparation of Vehicle .....	4.1	2
Preparation of MK .....	4.2	2
MK, Distribution, and Consumables .....	4.3	3
Tools and Test, Measurement, and Diagnostic Equipment (TMDE) Required .....	4.4	8
Installation Procedures .....	5.	9
Installation of Antenna, Vehicular, AS-3900/VRC (antenna) .....	5.1	11
Installation of Antenna Offset Mounting Brackets .....	5.1.1	11
Installation of Antenna Base .....	5.1.2	15
Installation of Top Antenna Assembly .....	5.1.3	18
Installation of Mounting Base, Electrical Equipment		

\*This manual supersedes TB 11-5820-890-20-102, 1 July 1997

MT-6352/VRC (mounting base) .....	5.2	19
Installation of Loudspeaker, Permanent Magnet LS-454/U (speaker) .....	5.3	21
Installation of Cables .....	5.4	22
Post-Installation and Checkout.....	5.5	27
Appendix A References.....		A-1

**LIST OF ILLUSTRATIONS**

Figure	Title	Page
4-1(1)	MK Illustrated Parts List.....	6
4-1(2)	MK Illustrated Parts List.....	7
5-1(1)	MK and Radio Installation: MK Equipment Locations.....	9
5-1(2)	MK and Radio Installation: Radio Equipment Locations.....	10
5-2(1)	Antenna Support Installation .....	13
5-2(2)	Antenna Mount Support .....	14
5-2(3)	Antenna Base Installation.....	16
5-2(4)	Antenna Mount Cover Installation .....	17
5-3	Top Antenna Assembly Installation.....	18
5-4	Mounting Base Installation .....	20
5-5	Installation of Loudspeaker, LS-454/U.....	21
5-6(1)	Cable Installation (RF Cabling) .....	23
5-6(2)	Installation of Cables: RF, Power, and SP Cabling .....	25
5-7	Cable Diagram: For AN/VRC-87/88/90 Series .....	28

**LIST OF TABLES**

Table	Title	Page
4-1	Parts List for Installation of Radio Set AN/VRC-87/88/90 Series .....	4

## 0.1 SCOPE.

This technical bulletin provides installation instructions for Installation Kit, Electronic Equipment MK-2845/VRC, commonly referred to as the Mounting Kit (MK). The MK shall be installed into the following type of vehicle(s):

- M56 Smoke Generator

The MK is used for installation of radio set components at field locations. The information contained in this technical bulletin is the official authorization to perform the installation at the unit maintenance level.

### NOTES

- This technical bulletin is not an authorization for requisition or turn-in of vehicles.
- This technical bulletin does not establish quantity or types of vehicles assigned to using units.

This technical bulletin does not contain information on the maintenance or replacement of the MKs. This information is contained in the MAC of TM 11-5820-890-20-2, TM 11-5820-890-20-4 and RPSTL of TM 11-5820-890-20P.

## 0.2 GENERAL INFORMATION.

The MK becomes operable when all the radio set components are installed in the vehicle and correct power is supplied. Refer to TM 11-5820-890-20-1 or TM 11-5820-890-20-4 for installation, Operational (OP) Check instructions, and required maintenance procedures. Refer to TM 11-5820-890-20P for repair parts.

Included in the radio set AN/VRC-87/88/90 Series is:

- Radio Set AN/VRC-87/88/90 Series (for RT-1523(C)/(U))

## 0.3 MAINTENANCE FORMS, RECORDS, AND REPORTS.

**0.3.1 Reports of Maintenance and Unsatisfactory Equipment.** See Section 4.2.2.3 for information.

**0.3.2 Report of Packing and Handling Deficiencies.** See Section 4.2.2.1 for information.

**0.3.3 Discrepancy in Transportation Deficiency Report (TDR) (SF361).** See Section 4.2.2.2 for information.

## 0.4 CONSOLIDATED INDEX OF ARMY PUBLICATIONS.

Refer to the latest issue of DA Pam 25-30 to determine whether there are new changes, or additional publications pertaining to the equipment.

## 1. PURPOSE OF INSTALLATION.

The Installation Kit Electronic Equipment MK-2845/VRC (MK) contains the items needed to mount Radio Set AN/VRC-87/88/90 Series in a M56 Smoke Generator (vehicle).

## 2. END ITEM OR SYSTEM TO BE MODIFIED.

Not applicable.

## 3. APPLICATION TIMES.

**3.1 Time for Completion of Installation.** Using two people, a total of 2.5 work hours is required. Typical vehicle downtime is 3 hours.

**3.2 Time for Installation of One Assembly or Component.** The following table lists the time required to install one component. All times have been rounded off to the nearest half hour. The sum of these items will not reflect the typical vehicle downtime.

ITEM	SECTION	TIME
Antenna AS-3900/VRC	5.1	0.5
Mounting Base, Electrical Equipment MT-6352/VRC	5.2	1.5
Cables	5.3	1.0

## 4. PREPARATION FOR INSTALLATION.

This section explains how to prepare the vehicle and MK for installation.

**4.1 Preparation of Vehicle.** To prepare the vehicle for installation, insure that the site includes adequate lighting and a power source when drilling is required. Inspect the vehicle for damage that could affect installation. Have any such damage repaired before installing MK.

**4.1.1 Items to be Removed.** Remove existing AN/VRC-12 radio family installation kit/harness. See TM 11-5820-401-20-2 for removing items used with intercom systems, or TM 11-5820-401-20-1 (used without intercom systems), and TM 9-2320-289-20.

**4.1.2 Items to be Retained.** Not applicable.

**4.2 Preparation of MK.** To prepare MK, unpack, inspect and check inventory.

**4.2.1 Precautions During Handling.** Observe these steps to prevent equipment damage.

- a. Keep dust cover in place on connectors.
- b. Do not disassemble or modify parts in MK unless authorized to do so.
- c. Keep mounting hardware covered and protected until needed.
- d. When exposed to moisture, rain or salt water, keep all parts dry to prevent corrosion.

**4.2.2 Unpack and Inspect Equipment.**

**4.2.2.1 Inspect Packaging for Evidence of Damage.** Any shipping damage should be reported on SF364 Report of Discrepancy (ROD) as prescribed in AR 735-11-2/DLAR 4140.55/NAVMATINST 4355.73A/AFR 400-64/MCO 4430.3F.

**4.2.2.2 Unpack and Inventory MK.** If any item is missing, fill out and forward Transportation Deficiency Report (TDR) (SF361) as described in AR 55-38/NAVSUPINST 4610.33C/AFR 75-18/MCO P4610.19D/DLAR 4500.15.

**4.2.2.3 Examine Each Item for Damage.** If any item is damaged, fill out and forward SF364 Report of Discrepancy (ROD) as prescribed in AR 735-11-2/DLAR 4140.55/NAVMATINST 4355.73A/AFR-400-64/MCO 4430.3F. All damages should be reported as prescribed in DA Pam 738-750, as contained in Maintenance Management Update.

**4.3 MK, Distribution and Consumables.**

**4.3.1 Items Supplied in MK and/or Required for Installation.** Use Table 4-1 and Figure 4-1 to identify and inventory MK parts supplied to install Radio Set AN/VRC-87/88/90 Series.

**4.3.2 Distribution and Issue Instructions.**

- a. US Forces: Do not requisition MK. They will be shipped automatically.
- b. US Army Depots: Requisition MK through supply channels.
- c. Multiservice: Instructions shall be included for multiservice modifications.
- d. MAP/MAS Countries: Instructions shall be provided for MAP/MAS countries.

Table 4.1. Parts List for Installation of Radio Set AN/VRC-87/88/90 Series

NSN	ITEM DESCRIPTION AND PART NUMBER	QUANTITY IN MK	SMR CODE	FIGURE, ITEM NO.
5985-01-297-2971	Antenna, Vehicular AS-3900/VRC (A3017899-1)	1	PAOOF A	4-1, 2
5305-00-847-1159	Screw, Cap, Hexagon (3/8-16 x 1 3/4 in) MS35307-365	4	PAOZZA	
5310-00-913-8881	Nut, Hexagon (3/8-16 in) MS51971-3	4	PAOZZA	
5310-00-061-1258	Washer, Lock, Internal/External-Toothed (3/8 in) MS45904-76	8	PAOZZA	
5310-00-889-2527	Washer, Lock, Internal/External-Toothed (5/16 in) MS45904-72	2	PAOZZA	
5306-00-225-9086	Bolt, Machine (5/16-24 x 5/8 in) MS90726-31 (Not Used)	1	PAOZZA	
5330-01-205-2864	Gasket (A3013655-1)	1	PAOZZA	
5975-01-188-8873	Mounting Base, Electrical Equipment MT-6352/VRC (A3013367-1)	1	PAOOF A	4-1, 1
5306-00-225-9089	Bolt, Machine (5/16-24 x 1 in) MS90726-34 (Not Used)	5	PAOZZA	
5310-00-889-2527	Washer Lock, Internal/External-Toothed (5/16 in) MS45904-72 (Not Used)	10	PAOZZA	
5310-00-880-7746	Nut, Hexagon (5/16-24 in) MS51968-5 (Not Used)	5	PAOZZA	
5995-01-225-1660	Cable Assembly, Radio Frequency, CG-3855/VRC (21 FT, 0 IN) (A3014031-17)	1	PAOZZA	4-1, 9
5995-01-219-2008	Cable Assembly, Special Purpose, Electrical, CX-13300/VRC (3 FT, 0 IN) (A3014044-2)	1	PAOZZA	4-1, 11
5995-01-274-5084	Cable Assembly, Power, Electrical, CX-13302/VRC 6 FT, 0 IN) (A3014039-5)	1	PAOZZA	4-1, 8
5995-01-303-4951	Cable Assembly, Special Purpose, Electrical CX-13313/VRC (2 FT, 7 IN) (A3018360-1)	1	PAOFF A	4-1, 12
4020-01-341-8795	Fiber Rope Assembly, Single Leg (A3167672-1)	1	PAOZZA	4-1, 7
5965-00-876-2375	Loudspeaker, Permanent Magnet, LS-454/U	1	PAOZZA	4-1, 3
	Cover, Antenna Mount (A3249860-1)	1	XBOZZA	4-1, 14
	Plate, Metal (A3249862-1)	1	XBOZZA	4-1, 10
	Antenna, Mount Offset (A3249857-1)	1	XBOZZA	4-1, 13
	Support, Antenna (A3249858-1)	1	XBOZZA	4-1, 6
	Plate, Metal (A3249861-1)	2	XBOZZA	4-1, 4
	Backing Plate, Antenna Weldment (A3249859-1)	1	XBOZZA	4-1, 5
5305-00-225-3839	Screw, Cap Hexagon (1/4-20 x 1 in) MS90725-8	3	PAOZZA	
5325-01-240-7325	Grommet, Nonmetallic 1/4 (A3013068-2)	1	PAOZZA	
5310-00-974-6623	Washer, Lock, IET (5/16 in) MS35338-140	4	PAOZZA	
5310-00-934-9751	Nut, Plain, Hexagon No. 10-32 MS35650-302	1	PAOZZA	
5975-00-111-3208	Strap, Tiedown, Electrical Components MS3367-5-9	10	PAOZZA	
5340-00-079-7837	Clamp, Loop (1/4-13/64 in) MS21333-67	7	PAOZZA	

Table 4.1. Parts List for Installation of Radio Set AN/VRC-87/88/09 Series. Continued

NSN	ITEM DESCRIPTION AND PART NUMBER	QUANTITY IN MK	SMR CODE	FIGURE, ITEM NO.
5340-00-809-1490	Clamp, Loop (1/4-1/4 in) MS21333-98	1	PAOZZA	
5310-00-045-3296	Washer, Lock No. 10 MS35338-43	11	PAOZZA	
5340-00-050-2740	Clamp, Loop (3/4-13/64 in) MS21333-75	3	PAOZZA	
5305-01-259-6322	Screw, Machine (No. 10-32 x 1/2 in) 12342499-1	8	PAOZZA	
5305-01-006-2025	Screw, Machine (No. 10-32 x 5/8 in) MS51849-65	2	PAOZZA	
5305-00-269-3213	Screw, Cap, Hexagon (3/8-16 x 1 1/4 in) MS90725-62	4	PAOZZA	
5305-00-068-0502	Screw, Cap, Hexagon (1/4-20 x 3/4 in) MS90725-6	4	PAOZZA	
5305-00-021-3740	Screw, Cap, Hexagon (3/8-16 x 1-1/2 in) MS35307-364	9	PAOZZA	
5306-00-225-8495	Screw, Cap, Hexagon (5/16-18 x 1/2 in) MS90725-30	4	PAOZZA	
5310-00-061-1258	Washer, Lock IET (3/8 in) MS45904-76	26	PAOZZA	
5310-00-809-4058	Washer, Lock (1/4 in) MS35338-44	6	PAOZZA	
5310-00-889-2528	Washer, Lock IET (1/4 in) MS45904-68	3	PAOZZA	
5310-00-761-6882	Nut, Plain, Hexagon (1/4-20 in) MS51967-2	7	PAOZZA	
5310-00-732-0558	Nut, Plain, Hexagon (3/8-16 in) MS51967-8	13	PAOZZA	



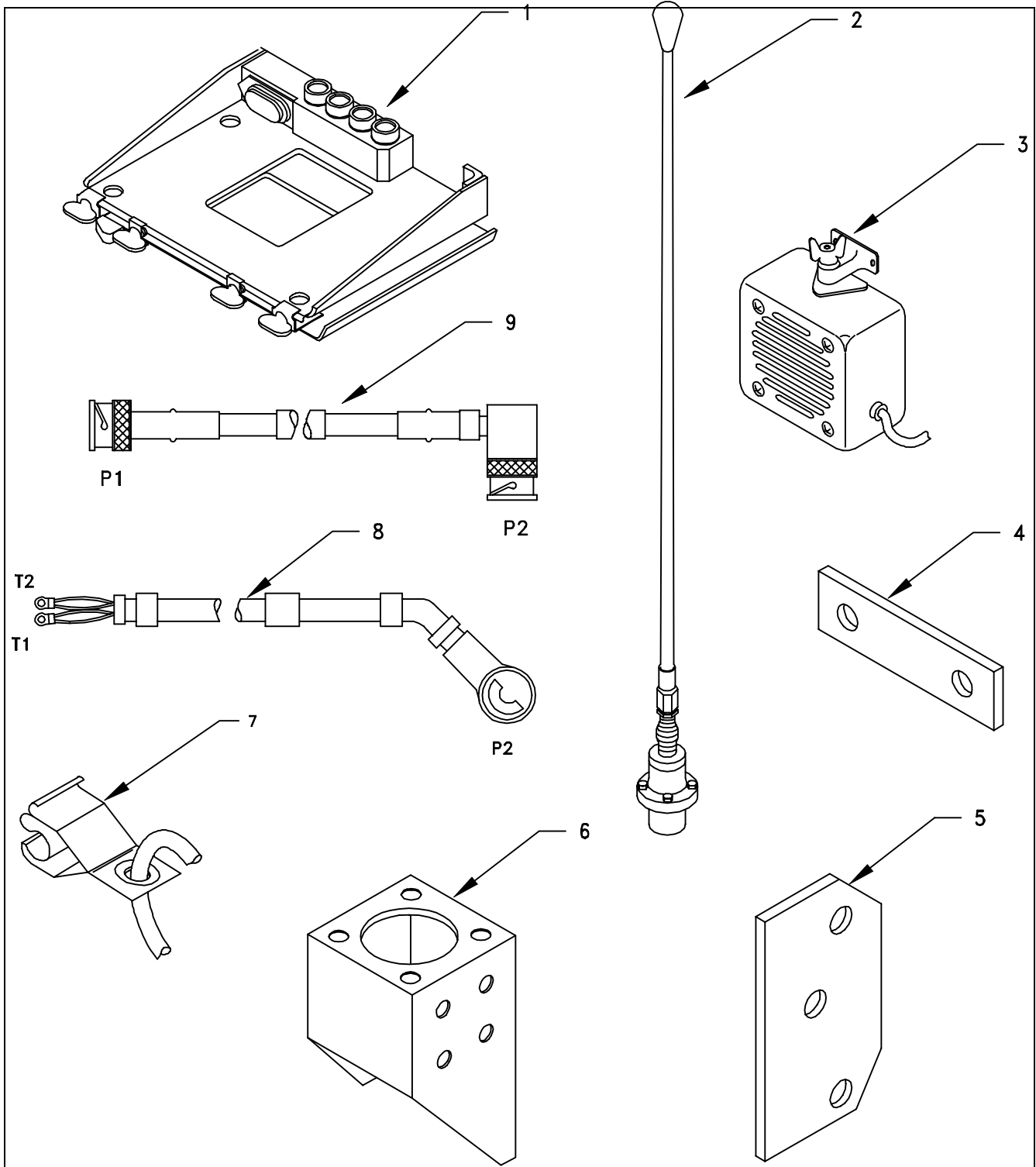

Figure 4-1(1). MK Illustrated Parts List

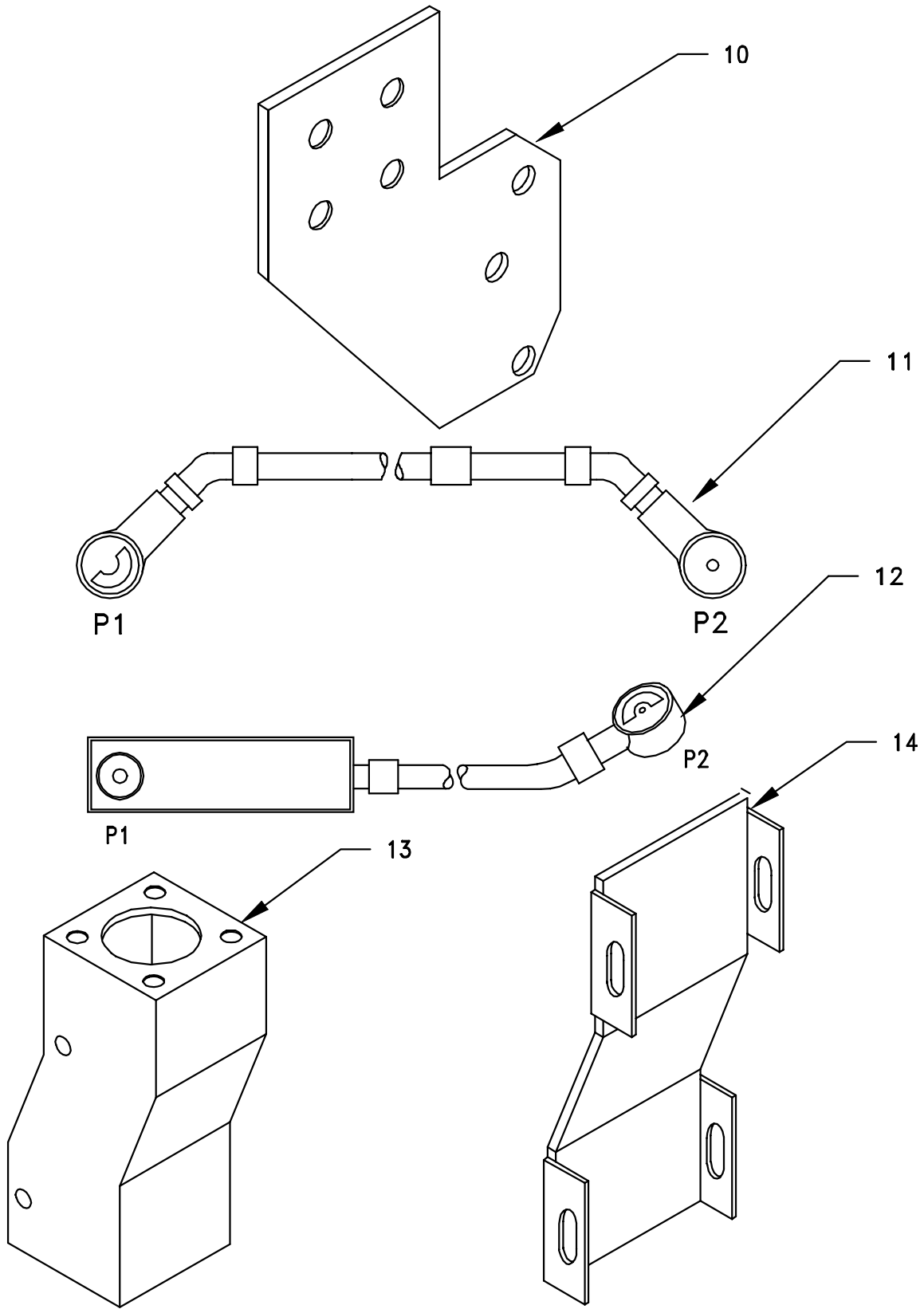

Figure 4-1(2). MK Illustrated Parts List

**4.3.3 Consumable Materials.** The table below lists materials required for installation but not supplied with MK.

NSN	NOMENCLATURE
8040-00-117-8510	Adhesive-Sealant, Clear, RTV
6850-00-880-7616	Silicone Compound, MIL-S-8660
8030-00-292-1102	Conductive Anti-seize Compound

**4.4 Tools and Test, Measurement, and Diagnostic Equipment (TMDE) Required.** The following tools and TMDE are needed for installation.

NOMENCLATURE	NSN	QUANTITY
Radio Set*		1
Electric Grinder or equivalent		1
Pocket Knife, Electrician's	5110-00-240-5943	1
Screwdriver, No. 2 Point Phillips, 4 in	5120-00-234-8913	1
Screwdriver, 1/4 in Flatblade, 4 in	5120-00-222-8852	1
Pliers, Round Nose	5120-00-240-6172	1
Pliers, Diagonal Cutting	5110-00-965-0974	1
Wrench, Open/Box:		
7/16 in	5120-00-228-9505	1
1/2 in	5120-00-228-9506	1
9/16 in	5120-00-228-9507	1
Handle, Socket Wrench:		
Socket		
7/16 in	5120-00-240-5364	1
1/2 in	5120-00-227-6703	1
9/16 in	5120-00-237-0977	1
9/16 in	5120-00-227-6704	1
Electric Drill		
Drill Bit		
9/32 in	5130-00-889-8994	1
13/32 in	5133-00-189-9246	1
13/32 in	5133-00-227-9686	1

\* Use radio issued with your vehicle if available.

## 5. INSTALLATION PROCEDURES.

This section describes where and how to install MK items in the vehicle. See Figure 5-1 for an overall view of where vehicular and MK equipment, as well as radio components, typically will be installed. When installing MK equipment, be sure to read and follow instructions and illustrations carefully.

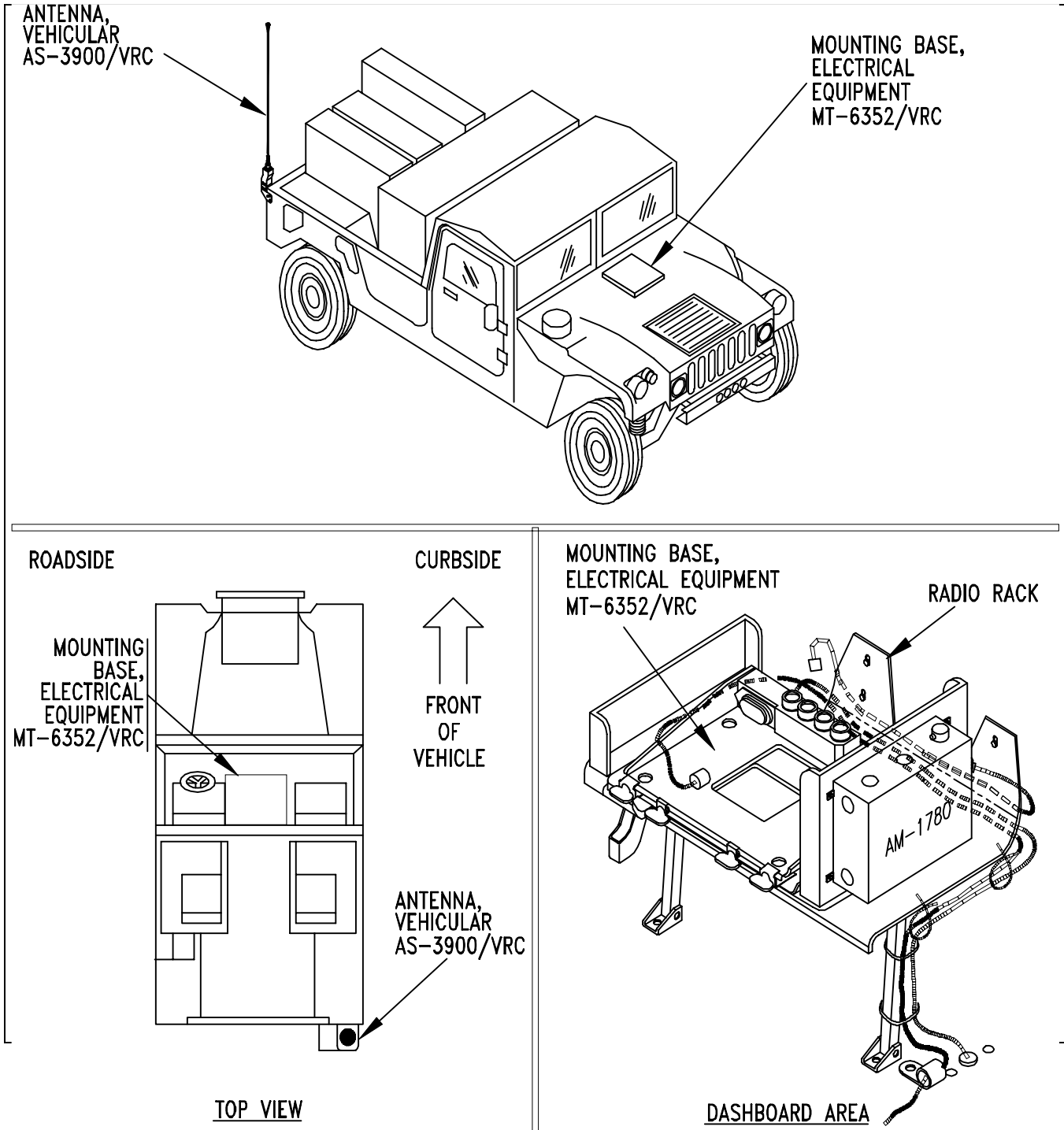
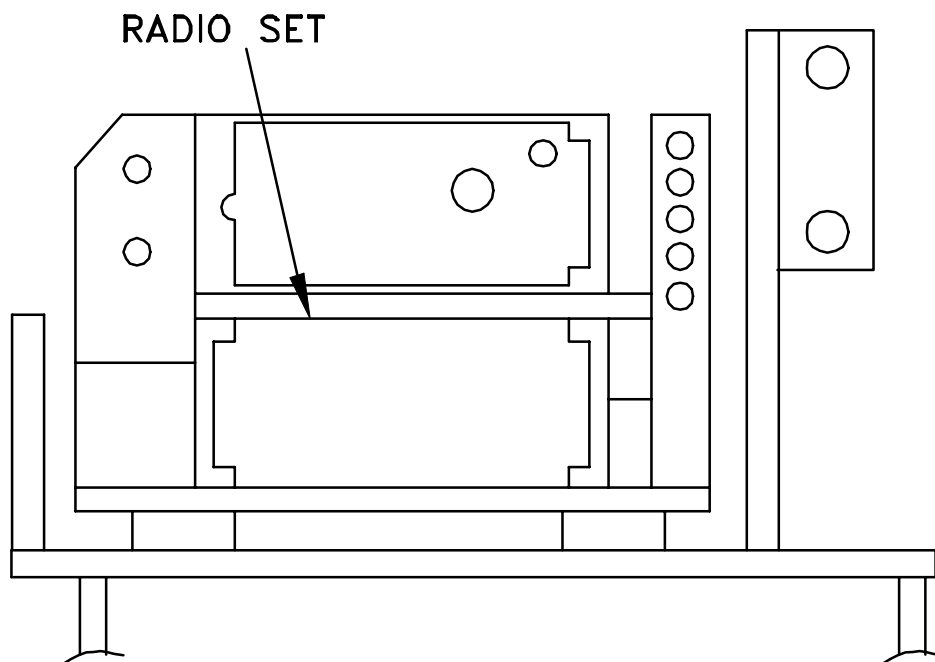

Figure 5-1(1). MK and Radio Installation: MK Equipment Locations

**5. INSTALLATION PROCEDURES.** Continued.

INSTALLATION FOR  
AN/VRC-87/88/90 SERIES



RADIO RACK

Figure 5-1(2). MK and Radio Installation: Radio Equipment Locations

## 5.1 Installation of Antenna, Vehicular, AS-3900/VRC (antenna).

**5.1.1 Installation of Antenna Offset Mounting Brackets.** Use the following procedures to install antenna offset mounting brackets. See Figure 5-1(1) for location.

ITEM	ACTION	REMARKS
<b>NOTE</b>		
Apply a thin coat of adhesive-sealant to both sides of each internal/external-toothed (IET) washer during installation, and to the area of contact where IET washer is to be placed.		
a. Antenna support bracket (1) and plate, metal (2).	Remove a 1" in diameter of paint around the four mounting holes on the mating surfaces of antenna support bracket (1) and plate, metal (2). Remove a 1" in diameter of paint around the three mounting holes on the mating surface side of the plate, metal (2) that will mate with the fender sponson. See Figure 5-2(1). Clean the paint removed areas and apply a thin coat of conductive anti-seize compound.	Tools: Electric grinder or equivalent.
b. Antenna support bracket (1), plate, metal (2), four cap screws (3), eight IET washers (4) and four nuts (5).	Attach plate, metal (2) to antenna support bracket (1). See Figure 5-2(1).	Tools: 9/16 in socket and 9/16 in open/box wrench.
c. Antenna support bracket (1) plate, metal (6).	Remove a 1" in diameter of paint around the two mounting holes from both sides of both plate, metal (6) and the two lower mounting holes of the mating surface of antenna support bracket (1). Remove a 1" in diameter of paint around the two existing holes in curbside rear of vehicle sponson on both sides of vehicle sponson. See Figure 5-2(1). Clean the paint removed areas and apply a thin coat of conductive anti-seize compound.	Tools: Electric grinder or equivalent.
d. Antenna support bracket (1), two plates, metal (6), two cap screws (3), four IET washers (4) and two nuts (5).	Temporarily Install to existing two holes in curbside rear of vehicle sponson. See Figure 5-2(1).	Tools: 9/16 in socket and 9/16 in open/box wrench.
e. Plate, metal (2).	Using plate, metal (2) already installed to antenna support bracket (1) as a template, drill three 13/32 in diameter holes through the curbside wheelwell. See Figure 5-2(1).	Tools: Electric drill and 13/32 in drill bit.
f. Antenna support bracket (1), two plates, metal (6), two cap screws (3), four IET washers (4) and two nuts (5) installed in step d.	Temporarily de-install.	Tools: 9/16 in socket and 9/16 in open/box wrench.

5.1.1 Installation of Antenna Offset Mounting Brackets. Continued.

ITEM	ACTION	REMARKS
g. Antenna weldment backing plate (7).	Remove a 1" in diameter of paint around the three mounting holes of the mating surface to the fender sponson. Remove a 1" in diameter of paint around the three mounting holes drilled in the fender sponson in step e on both sides of the fender sponson. See Figure 5-2(1). Clean paint removed areas and apply a thin coat of conductive anti-seize compound.	Tools: Electric grinder or equivalent.
h. Antenna support bracket (1), two plates, metal (6), two cap screws (3), four IET washers (4) and two nuts (5) de-installed in step f.	Install and secure.	Tools: 9/16 in socket and 9/16 in open/box wrench.
i. Plate, metal (2), antenna weldment backing plate (7), three cap screws (3), six IET washers (4), and three nuts (5).	Install and secure to vehicle wheelwell. See Figure 5-2(1).	Tools: 9/16 in socket and 9/16 in open/box wrench.
j. Antenna offset (1) and antenna support bracket (2).	Remove a 1" in diameter of paint around the four mounting holes on the mating surfaces of antenna offset (1) and antenna support bracket (2). See Figure 5-2(2). Clean paint removed areas and apply a thin coat of conductive anti-seize compound.	Tools: Electric grinder or equivalent.
k. Antenna offset (1).	Place on antenna support bracket (2) and align mounting holes. See Figure 5-2(2).	
l. Four cap screws (3), eight IET washers (4) and four nuts (5).	Install and secure to antenna mount offset (1) and antenna support bracket (2). See Figure 5-2(2).	Tools: 9/16 in socket and 9/16 in open/box wrench.

5.1.1 Installation of Antenna Offset Mounting Brackets. Continued.

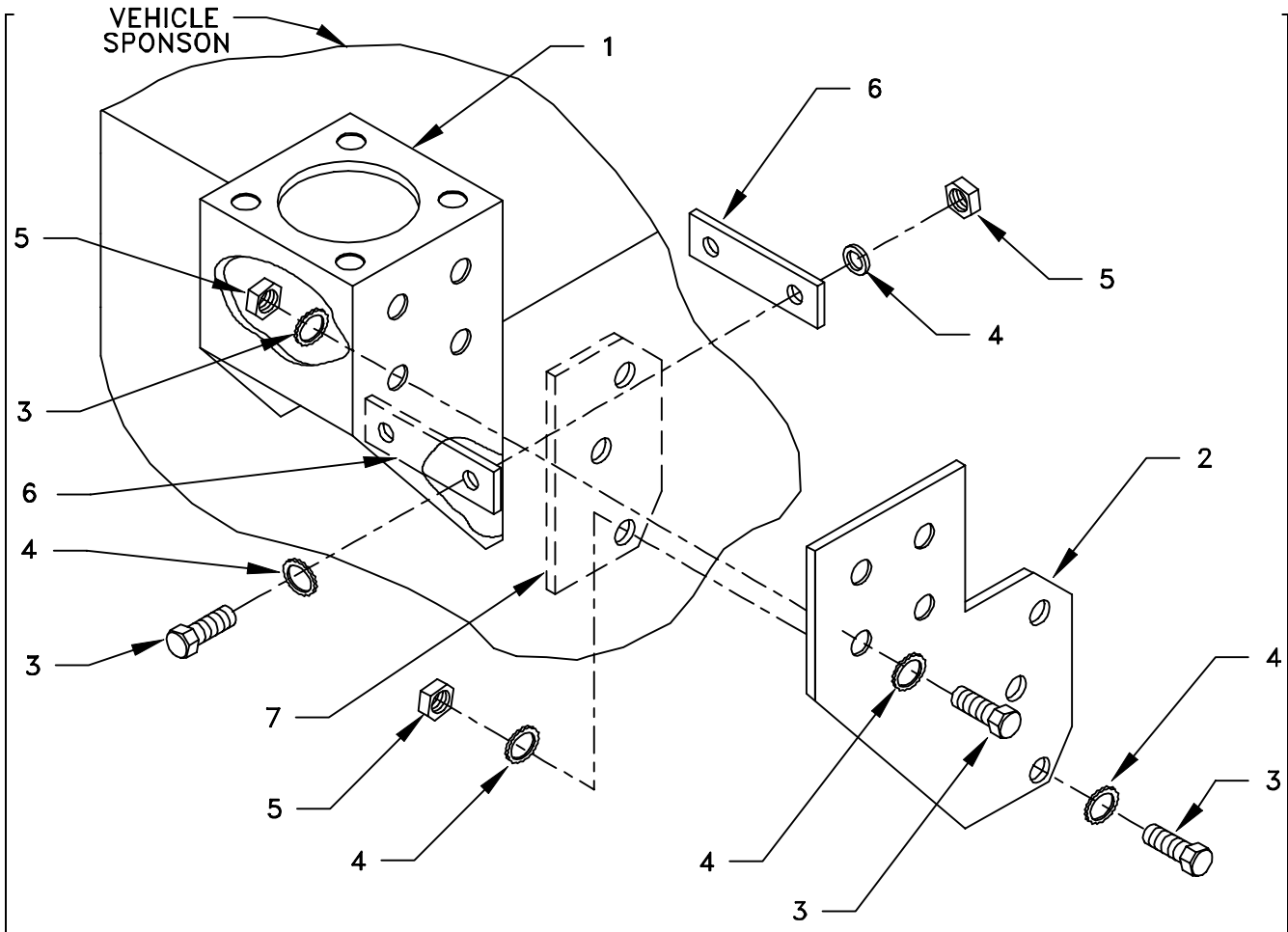

- 1. ANTENNA SUPPORT BRACKET
- 2. PLATE, METAL
- 3. CAP SCREW (3/8-16 X 1 1/2 IN)
- 4. IET WASHER (3/8 IN)
- 5. NUT (3/8-16 IN)
- 6. PLATE, METAL
- 7. BACKING PLATE, ANTENNA WELDMENT

Figure 5-2(1). Antenna Support Installation



5.1.1 Installation of Antenna Offset Mounting Brackets. Continued.

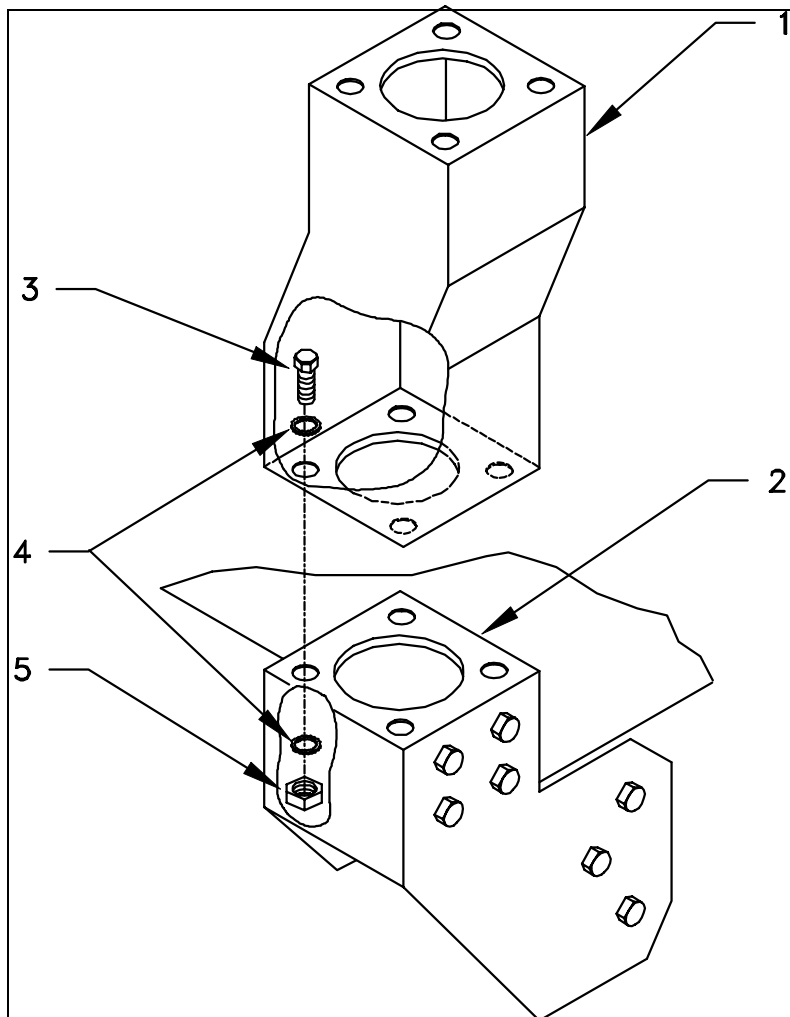

1. ANTENNA MOUNT OFFSET
2. ANTENNA SUPPORT BRACKET
3. CAP SCREW (3/8-16 X 1 1/2 IN)
4. IET WASHER (3/8 IN)
5. NUT (3/8 IN)

Figure 5-2(2). Antenna Mount Offset Installation

**5.1.2 Installation of Antenna Base.** Use this procedure to install antenna base. See Figure 5-1(1) for location.

ITEM	ACTION	REMARKS
<b>NOTE</b>		
Apply a thin coat of adhesive-sealant to both sides of each internal/external-toothed (IET) washer during installation, and to the area of contact where IET washer is to be placed.		
a. Gasket (3).	Place on antenna mount offset (2) and align mounting holes. See Figure 5-2(3).	
b. Antenna base (1).	Place on top of gasket (3) and antenna mount offset (2) and align mounting holes.	
c. Four cap screws (4), eight IET washers (5) and four nuts (6).	Install and secure to antenna base (1) and antenna mount offset (2).	Tools: 9/16 in socket and 9/16 in open/box wrench.
d. Ground strap (7), cap screw (8), three IET washers (9) and nut (10).	Install and secure to hole in antenna mount offset (2). See Figure 5-2(3), Detail A. Note: Mounting hole may have to be enlarged to 9/32 in.	Tools: 7/16 in socket and 7/16 in open/box wrench.
e. RF cable (11) connector P1.	Connect and secure to antenna base (1) connector J1.	
f. Cover, antenna mount (2), four cap screws (3) and four lock washers (4).	Install and secure to antenna mount offset (1). See Figure 5-2(4).	Tools: 1/2 in socket.

5.1.2 Installation of Antenna Base. Continued.

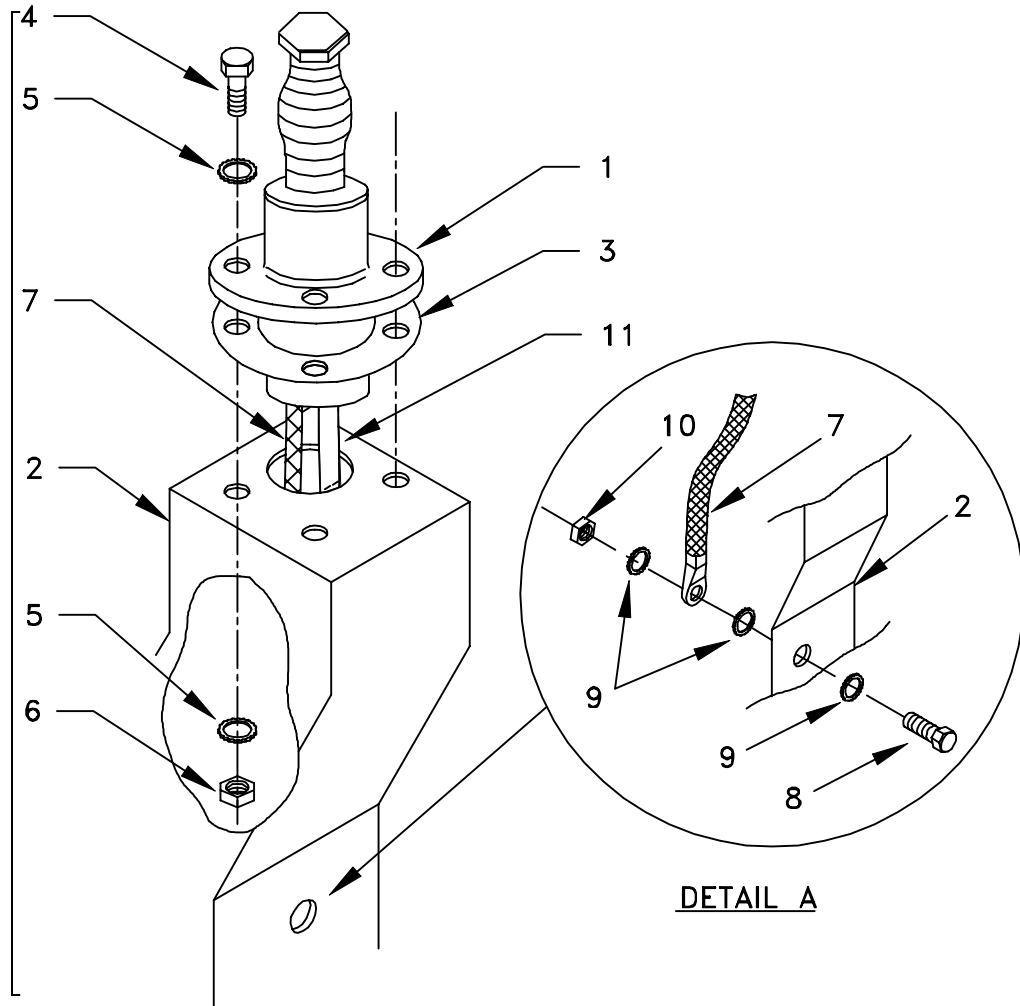

- |  |   |
|--|---|
| <ul style="list-style-type: none"> <li>1. ANTENNA BASE</li> <li>2. ANTENNA MOUNT OFFSET</li> <li>3. GASKET</li> <li>4. CAP SCREW (3/8-16 X 1-3/4)</li> <li>5. IET WASHER (3/8 IN)</li> <li>6. NUT (3/8-16 IN)</li> </ul> | <ul style="list-style-type: none"> <li>7. GROUND STRAP (P/O ANTENNA)</li> <li>8. CAP SCREW (1/4-20 X 1 IN)</li> <li>9. IET WASHER (1/4 IN)</li> <li>10. NUT (1/4-20 IN)</li> <li>11. RF CABLE, CG-3855/VRC (21 FT, 0 IN)</li> </ul> |
|--|---|

Figure 5-2(3). Antenna Base Installation

5.1.2 Installation of Antenna Base. Continued.

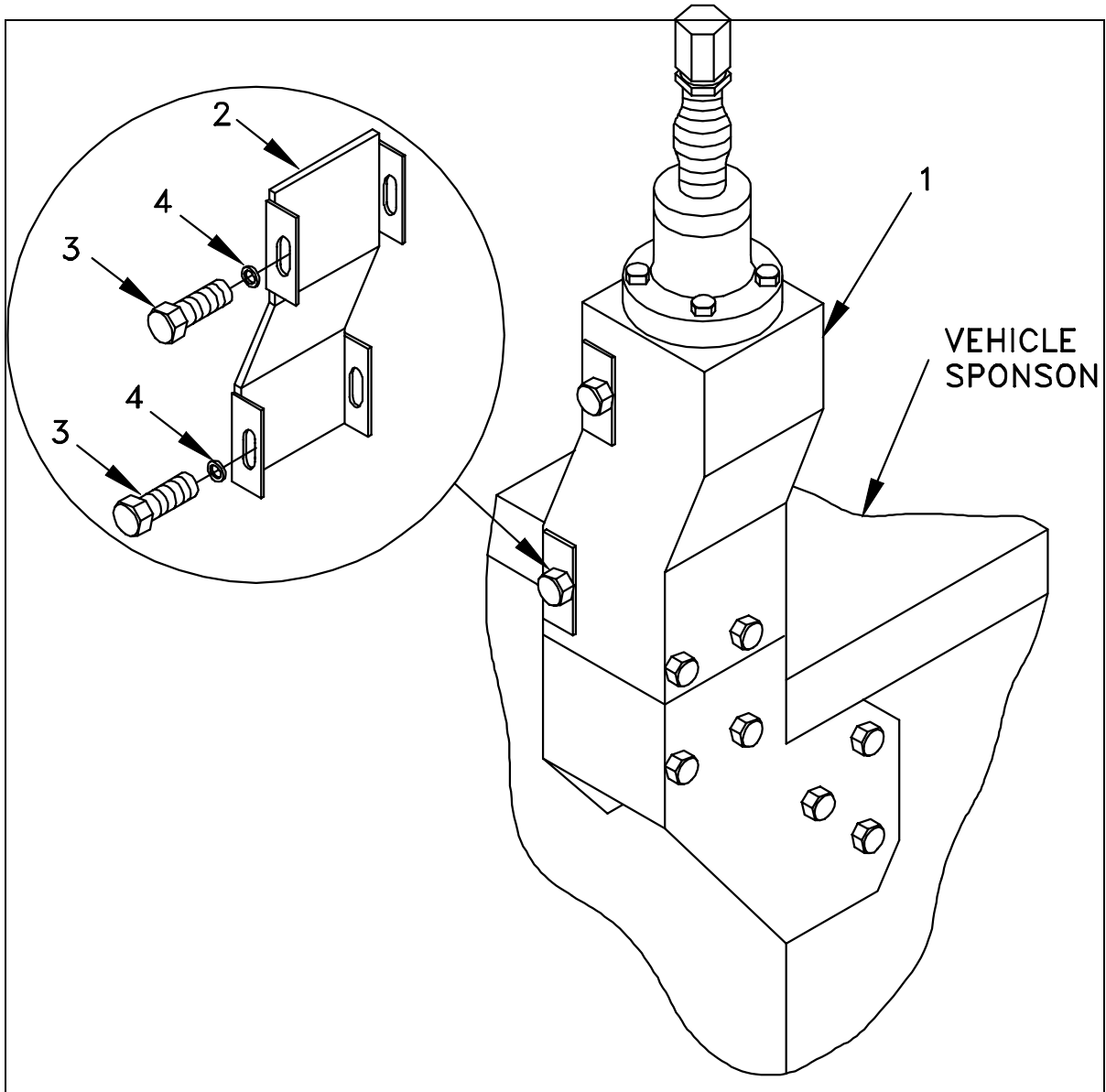

1. ANTENNA MOUNT OFFSET
2. COVER, ANTENNA MOUNT
3. CAP SCREW (5/16-18 X 1/2)
4. LOCK WASHER (5/16 IN)

Figure 5-2(4). Antenna Mount Cover Installation

**5.1.3 Installation of Top Antenna Assembly.** The top portion of the antenna includes a lower element and an upper element (with installed cap). Use the following procedure to assemble, install and tie down all antennas.

ITEM	ACTION	REMARKS
a. Antenna elements (1, 2).	Apply silicone compound to element threads and assemble. See Figure 5-3.	
b. Antenna element (2).	Install and hand tighten to antenna base (3).	
c. Lock wire (4).	Install to antenna element (2) and antenna base (3). See Figure 5-3, Detail A.  Cut and remove excess wire with diagonal cutting pliers.	
d. Fiber rope assembly (5).	Attach clip to antenna element (1). Tie rope to vehicle to position antenna in desired location. See Figure 5-3, Detail B.	

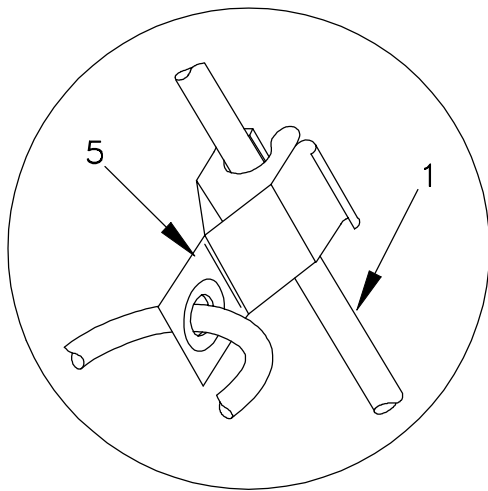

DETAIL B

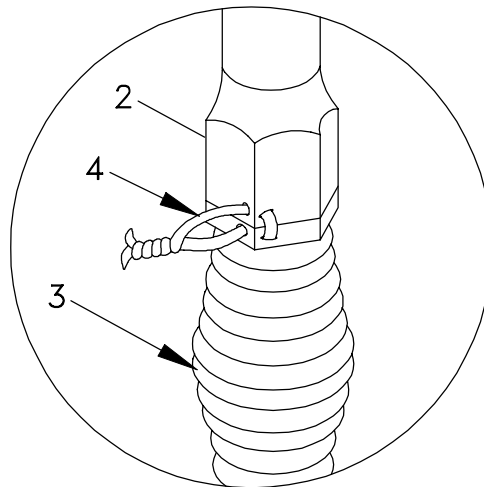

DETAIL A

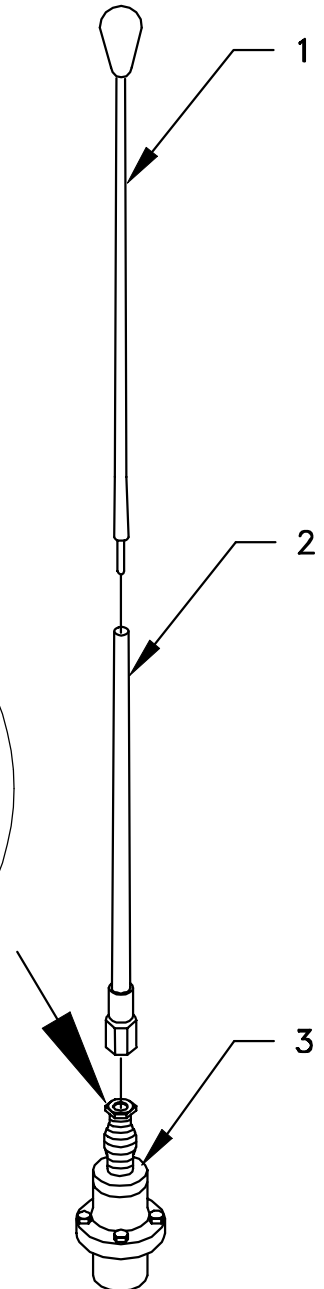

- 1. ANTENNA ELEMENT (UPPER)
- 2. ANTENNA ELEMENT (LOWER)
- 3. ANTENNA BASE
- 4. LOCK WIRE
- 5. FIBER ROPE ASSEMBLY

Figure 5-3. Top Antenna Assembly Installation

**5.2 Installation of Mounting Base, Electrical Equipment MT-6352/VRC (mounting base).** Remove and discard attaching bag of 5/16 mounting hardware. To insure good electrical grounding, any rust, corrosion or paint around mounting holes in mounting plate should be removed before installing the mounting base.

ITEM	ACTION	REMARKS
<b>NOTE</b>		
Apply a thin coat of adhesive-sealant to both sides of each internal/external-toothed (IET) washer during installation, and to the area of contact where IET washer is to be placed.		
a. Mounting holes for mounting base (1).	Remove and retain existing hardware (screws, IET washers, and nuts) from four holes in existing mounting plate and existing radio rack. See Figure 5-4.	Tools: 1/2 in socket and 1/2 in open/box wrench.
b. Mounting base (1) and existing radio rack.	Remove a 2" square area of paint on the underside of the mounting base (1) around the left front and rear mounting holes. Remove a 2" square area of paint on the top of the existing radio rack mating with the left mounting holes of the mounting base (1). Clean the paint removed areas and apply a thin coat of conductive anti-seize compound.	Tools: Electric grinder or equivalent.
c. Mounting base (1).	Place on existing radio rack over existing holes.	
d. Two outer thumbscrews (2).	Turn ccw until both sets of threads have cleared center of holes.	
e. Mounting base (1).	Align four holes with matching hole pattern with existing radio rack.	
f. Existing hardware removed and retained in step a.	Install and tighten to mounting base (1) and existing and radio rack.	Tools: 1/2 in socket and 1/2 in open/box wrench.
g. Two outer thumbscrews (2).	Tighten and secure.	

5.2 Installation of Mounting Base, Electrical Equipment MT-6352/VRC (mounting base). Continued.

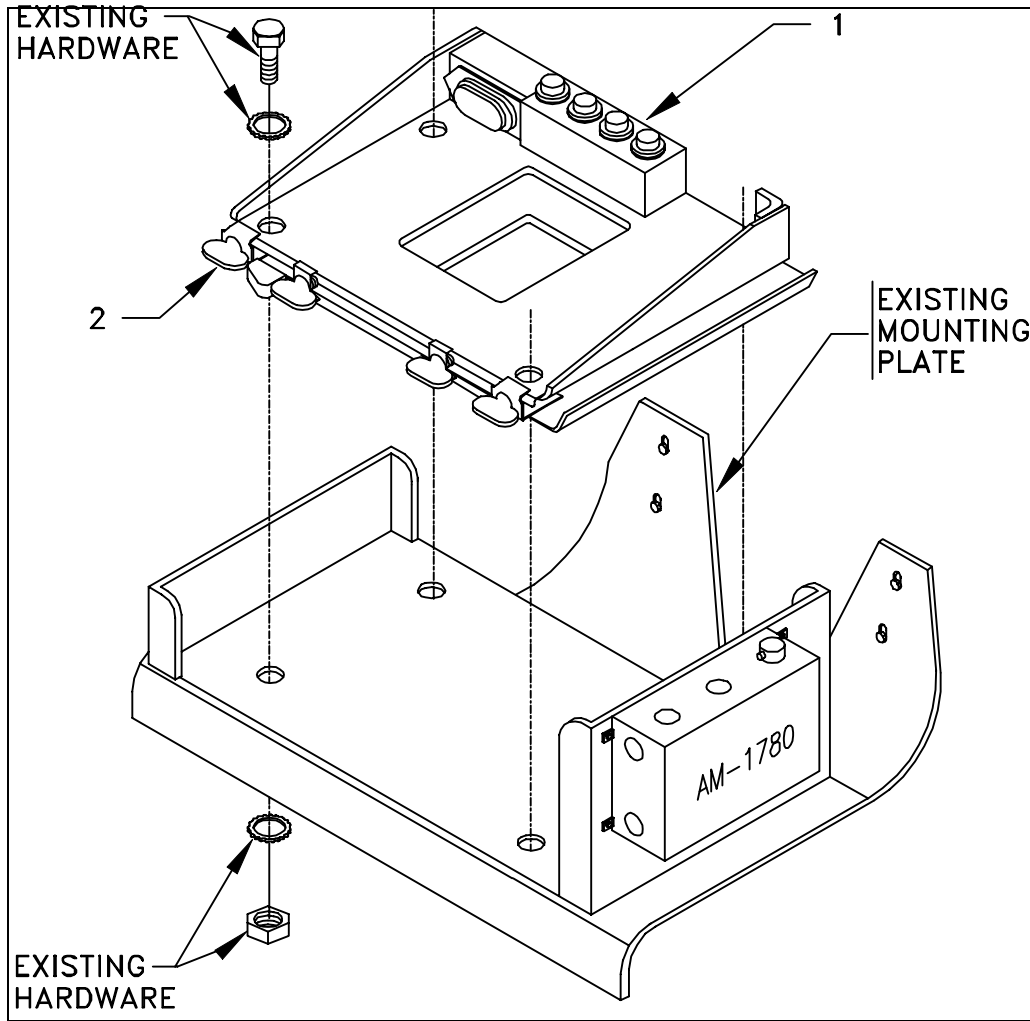

- 1. MOUNTING BASE
- 2. THUMBSCREW

Figure 5-4. Mounting Base Installation

**5.3 Installation of Loudspeaker, Permanent Magnet LS-454/U (speaker).** Use the following procedures to install LS-454/U speaker.

ITEM	ACTION	REMARKS
a. Mounting surface.	In the cab, locate existing bracket attached to the existing electrical equipment shelf. See Figure 5-5.	
b. Speaker (1), two cap screws (2), two lock washers (3) and two nuts (4).	Install and secure to existing mounting holes in existing bracket. See Figure 5-5.	Tools: 7/16 in socket and 7/16 in open/box wrench.

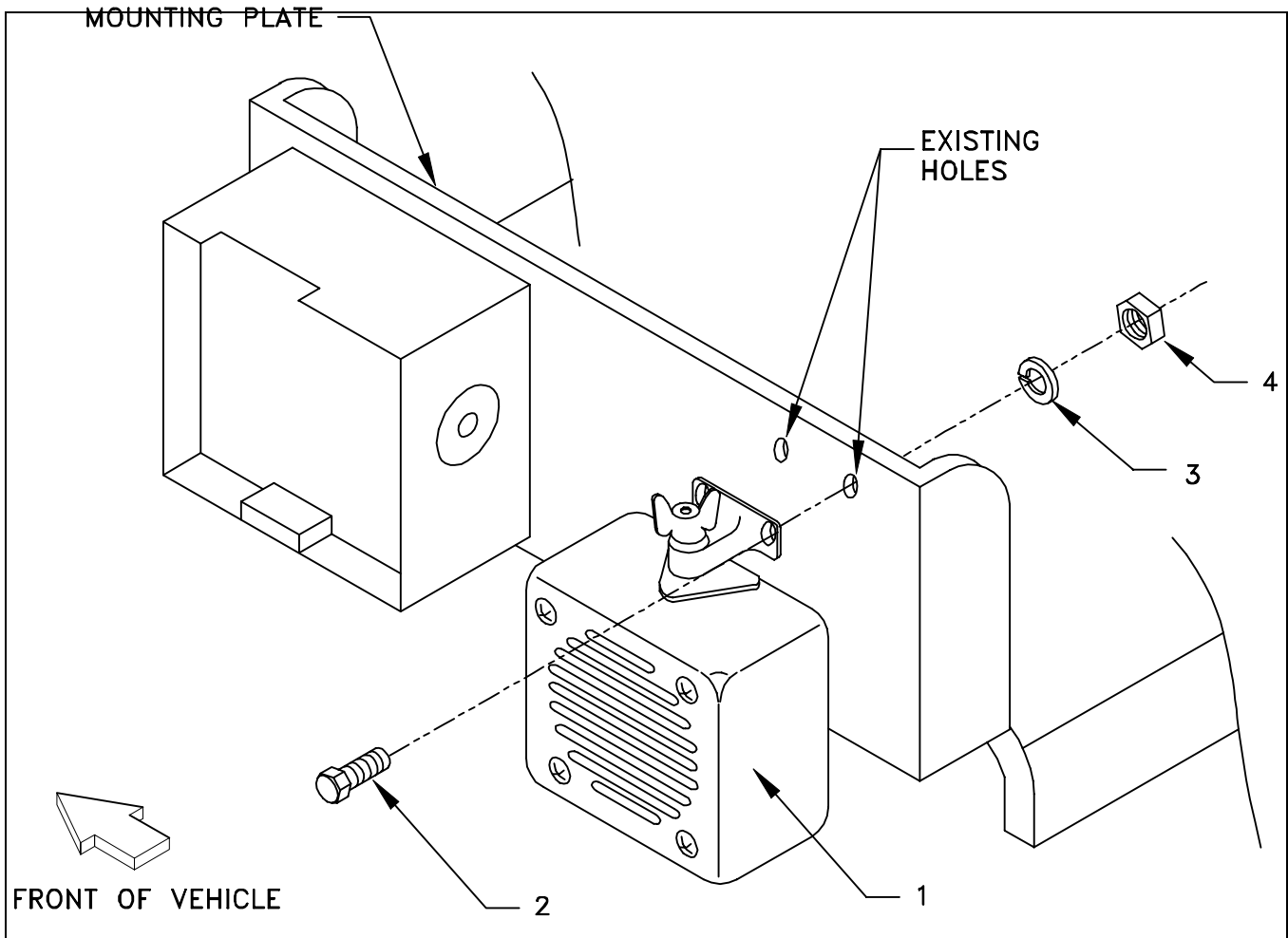

- 1. LS-454/U LOUDSPEAKER
- 2. CAP SCREW (1/4-20 X 1 IN)
- 3. LOCK WASHER (1/4 IN)
- 4. NUT (1/4-20 IN)

Figure 5-5. Installation of Loudspeaker, LS-454/U



**5.4 Installation of Cables.** To accomplish the installation, leave loop clamps and tiedown straps loose enough to adjust cable slack and allow easy adjustment of equipment. When installation is complete, tighten and secure all clamps, clips and tiedown straps.

**WARNING**

Make sure vehicle power source is positioned OFF or disconnected before installing cables.

ITEM	ACTION	REMARKS
a. RF cable (1).	Insert through existing grommet hole in rear wall. See Figure 5-6(1).	
b. Grommet (7).	Cut through on mark shown; then wrap around RF cable (2) and install to grommet hole in rear wall. See Figure 5-6(1), Detail A.	Tools: Pocket knife.
c. RF cable (1).	Route forward along bottom of frame to existing grommet and retainer. See Figure 5-6(1).	
d. Loop clamp (4) and existing mounting hardware.	Wrap around RF cable (1); then install to rear reflector (on inside corner of rear curbside wall).	
e. Tiedown strap (5).	Wrap around RF cable (1), then install loosely to taillight wiring harness. See Figure 5-6(1) for location.	
f. Loop clamp (2) machine screw (No. 10-32 x 5/8 in), lock washer (No. 10) and nut (No. 10-32 in).	Wrap clamp around RF cable (1) and existing harness; then install to bottom edge of rear wall.	Tools: 5/16 in socket and 5/16 in open/box wrench.
g. Two loop clamps (3), three loop clamps (6), five machine screws (No. 10-32 x 1/2 in) and five lock washers (No. 10).	Wrap clamps around RF cable (1) and existing cable harness; then install to mounting holes on bottom of rear curbside frame.	Tools: 5/16 in socket.
h. Existing grommet and retainer.	Temporarily remove from grommet hole in rear curbside wheelwell. Discard mounting hardware. See Figure 5-6(1), Detail B.	
i. RF cable (1).	Insert through grommet hole; then route cable through utility compartment area to radio rack. See Figure 5-6(1).	
j. Existing grommet (removed in step h).	Wrap around RF cable (1); then insert in grommet hole. See Figure 5-6(1), Detail B.	
k. Existing retainer, two cap screws (8), two lock washers (9) and two nuts (10).	Install and secure grommet and wheelwell. See Figure 5-6(1), Detail B.	Tools: 7/16 in socket.

5.4 Installation of Cables. Continued.

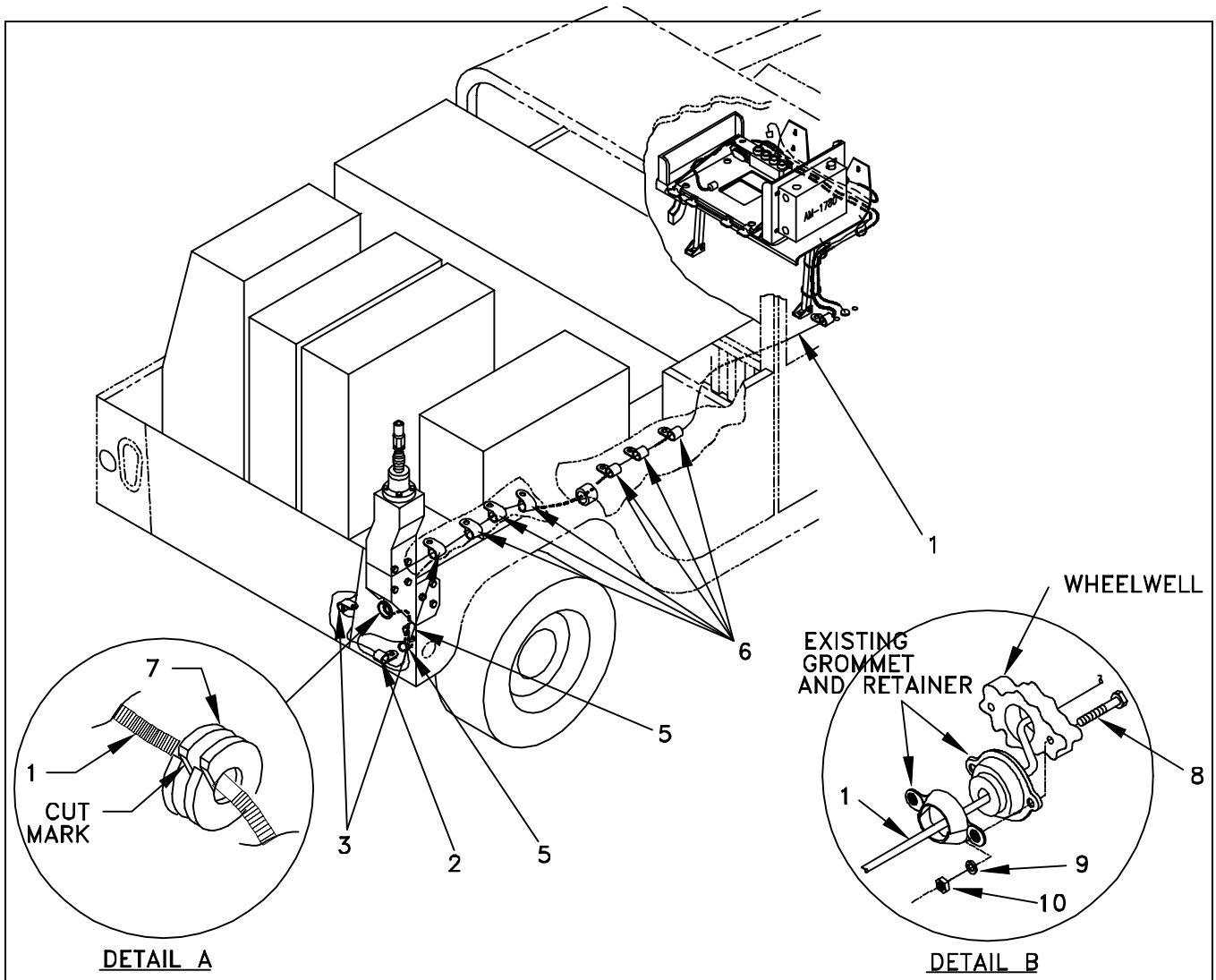

- |   |  |
|---|--|
| <ul style="list-style-type: none"> <li>1. RF CABLE, CG-3855/VRC (21 FT, 0 IN)</li> <li>2. LOOP CLAMP (3/4-13/64 IN)<br/>MACHINE SCREW (NO. 10-32 X 5/8 IN)<br/>LOCK WASHER (NO. 10)<br/>NUT (NO. 10-32 IN)</li> <li>3. LOOP CLAMP (3/4-13/64 IN)<br/>MACHINE SCREW (NO. 10-32 X 1/2 IN)<br/>LOCK WASHER (NO. 10)</li> <li>4. LOOP CLAMP (1/4-1/4 IN)</li> </ul> | <ul style="list-style-type: none"> <li>5. TIEDOWN STRAP</li> <li>6. LOOP CLAMP (1/4-13/64 IN)<br/>MACHINE SCREW (NO. 10-32 X 1/2 IN)<br/>LOCK WASHER (NO. 10)</li> <li>7. GROMMET</li> <li>8. CAP SCREW (1/4-20 X 3/4 IN)</li> <li>9. LOCK WASHER (1/4 IN)</li> <li>10. NUT (1/4-20 IN)</li> </ul> |
|---|--|

Figure 5-6(1). Cable Installation: RF Cabling

5.4 Installation of Cables. Continued.

ITEM	ACTION	REMARKS
l. Three loop clamps (6), three machine screws (No. 10-32 x 1/2) and three lock washers (No. 10).	Drill three 5/32 in diameter holes in vehicle floor; then wrap clamps around RF cable (1) and install to holes with indicated hardware. See Figure 5-6(1) for approximate location(s).	Tools: Electric drill, 5/32 in drill bit, and 5/16 in socket..
m. Front curbside floor padding.	Secure over RF cable (1).	
n. Loop clamp (3), machine screw (No. 10-32 x 5/8 in), and lock washer (No. 10).	Wrap clamp around RF cable (1), then install behind curbside leg support. See Figure 5-6(2).	Tools: 5/16 in socket.
o. RF cable (1).	Route up curbside leg support then rearward along radio rack then route under radio rack toward the roadside and position on top of mounting base (2). See Figure 5-6(2).	
p. SP cable (4) connector P1.	Connect and secure to AM-1780/VRC connector J501. See Figure 5-6(2).	
q. SP cable (4).	Route under radio rack to rear of mounting base (2).	
r. SP cable (5) connector P2.	Connect and secure to mounting base (2) connector J3. See Figure 5-6(2), Detail C.	
s. SP cable (4) connector P2.	Connect and secure to SP cable (5) connector P1; then position behind mounting base (2).	
t. Power cable (6) connector P2.	Position on top of mounting base (2).	
u. Power cable (6).	Route under radio rack to existing grommet location behind loop clamp (3).	
v. Existing grommet and retainer.	Temporarily remove from grommet hole. Discard mounting hardware. See Figure 5-6(2), Detail A.	
w. Power cable (6).	Insert through grommet hole to underbody of vehicle; then position T1 and T2 terminal leads near terminal lugs. See Figure 5-6(2), Detail B.	
x. Power cable (6) terminal leads: T1 (red) and T2 (black).	Connect and secure to terminal lugs with existing mounting hardware.	
y. Existing grommet (removed in step v).	Wrap around power cable (6) then insert in grommet hole. See Figure 5-6(2), Detail A.	
z. Existing retainer, two cap screws (7), two lock washers (8) and two nuts (9).	Install and secure to grommet and underbody.	Tools: 7/16 in socket and 7/16 in open/box wrench.

5.4 Installation of Cables. Continued.

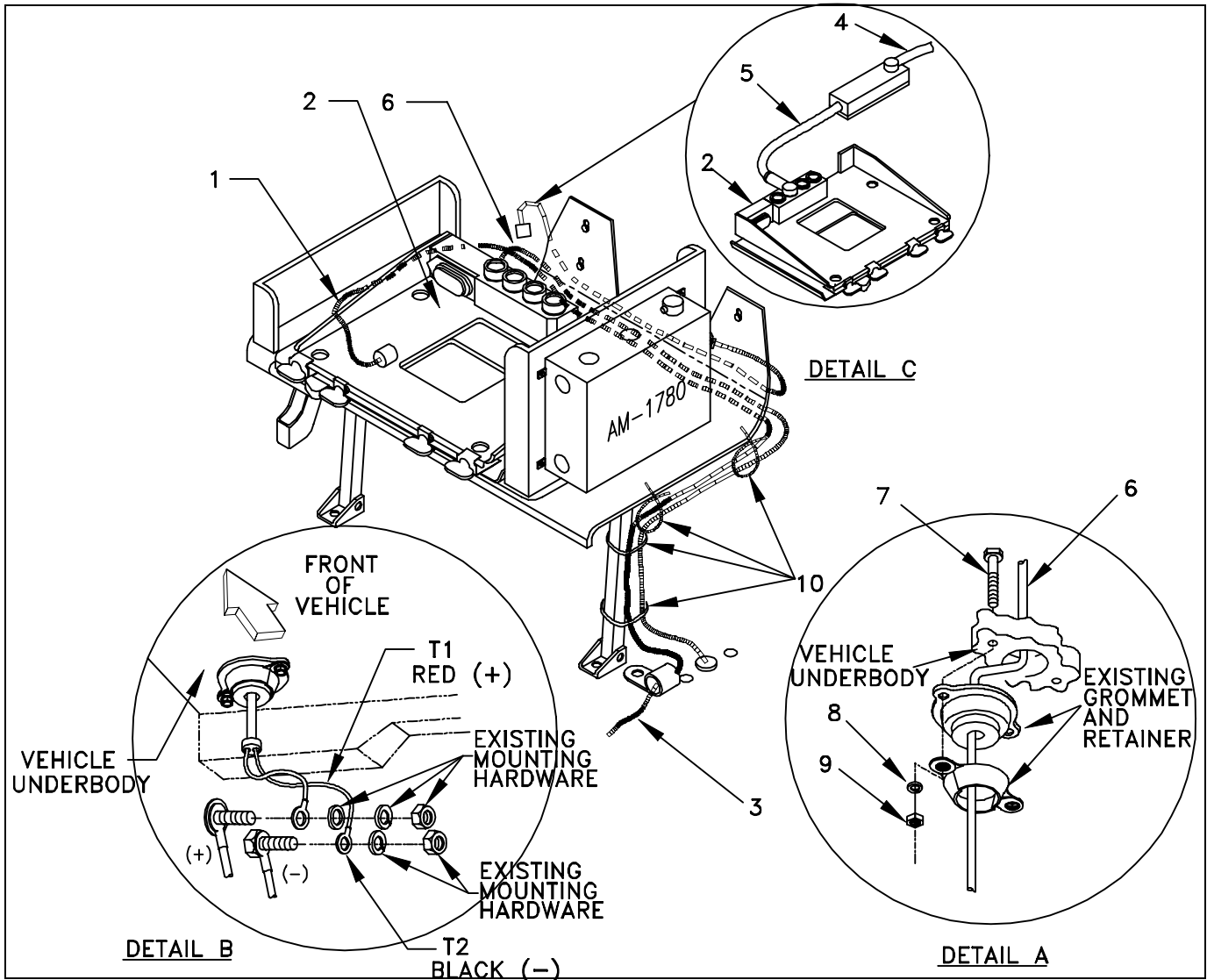

- 1. RF CABLE, CG-3855/VRC (21 FT, 0 IN)
- 2. MOUNTING BASE
- 3. LOOP CLAMP (1/4-13/64 IN)  
MACHINE SCREW (NO. 10-32 X 5/8 IN)  
LOCK WASHER (NO. 10)
- 4. SP CABLE, CX-13300/VRC (3 FT, 0 IN)

- 5. SP CABLE, CX-13313/VRC (2 FT, 7 IN)
- 6. POWER CABLE , CX-13302/VRC (6 FT, 0 IN)
- 7. CAP SCREW (1/4-20 x 3/4 IN)
- 8. LOCK WASHER (1/4 IN)
- 9. NUT (1/4-20 IN)

Figure 5-6(2). Installation of Cables: RF, Power, and SP Cabling

**5.4 Installation of Cables.** Continued.

ITEM	ACTION	REMARKS
aa. Four tiedown straps (10).	Wrap two tiedown straps (10) around power cable (6) and RF cable (1) near curbside edge of radio rack; then wrap two around power cable and RF cable and secure loosely to curbside leg support.	
ab. Power cable (6) connector P2.	Connect and secure to mounting base (2) connector J1.	

**5.5 Post-Installation and Checkout.** After equipment is installed and cables are connected, perform the following steps.

ITEM	ACTION	REMARKS
a. Equipment.	Check for secure mounting. Check for loose parts, connectors, and mounting hardware.	
b. Cables.	Check for proper installation and connection of cables. See figure 5-7 for cable connections. Unused cables should be stowed in appropriate place inside the vehicle.	
c. Loop clamps.	Check that all have been properly installed and tightened.	
d. Protective covers.	Insure that all installed cables are covered when not in use or connected.	
e. Radio issued with vehicle.	Install and connect cables. See TM 11-5820-890-20-1 or TM 11-5820-890-20-4 for installation and operational (OP) checks and instructions.	
f. MK line replaceable units.	See TM 11-5820-890-20P for Repair Parts and Special Tools List (RPSTL) information.	

5.5 Post-Installation and Checkout. Continued.

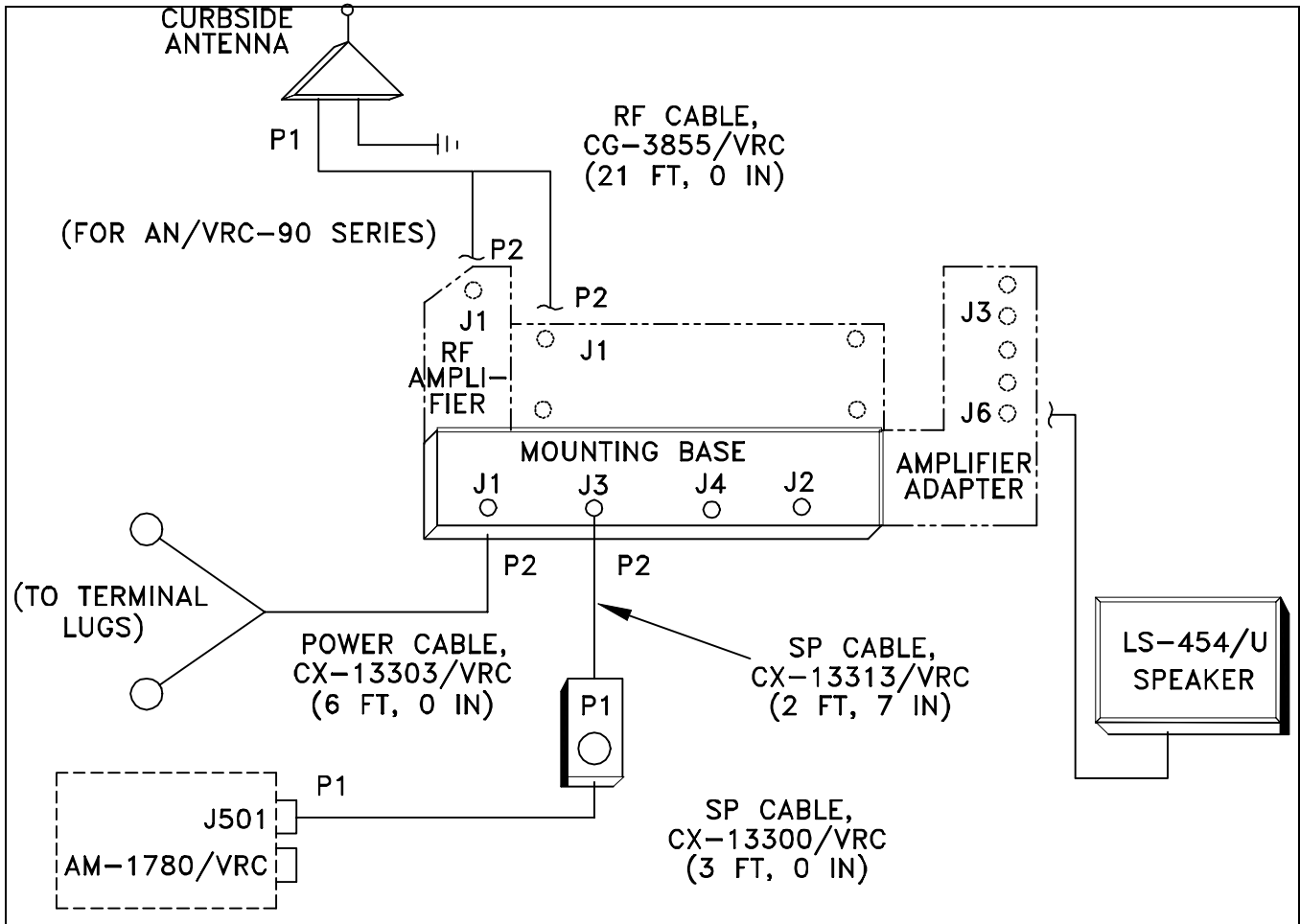

Figure 5-7. Cable Diagram: For AN/VRC-87/88/90 Series

5.5 Post-Installation and Checkout. Continued.

CABLE ASSEMBLY	FROM			TO		
	CABLE CONN.	UNIT	UNIT CONN.	CABLE CONN.	UNIT	UNIT CONN.
CX-13302/VRC (6 FT, 0 IN)	P2	Mounting base	J1	T1: Red (+) T2: Black (-)	Terminal lugs	(+) Post (-) Post
CG-3855/VRC (21 FT, 0 IN)	P1	Curbside antenna base	J1	P2	RF amplifier or RT	J1
CX-13300/VRC (3 FT, 0 IN)	P2	CX-13313/VRC (2 FT, 7 IN)	P1	P1	AM-1780/VRC	J501
CX-13313/VRC (2 FT, 7 IN)	P1	CX-13300/VRC (3 FT, 0 IN)	P2	P2	Mounting base	J3
Speaker cable		LS-454/U speaker			Amplifier-adapter	J6

Figure 5-7. Cable Diagram: For AN/VRC-87/88/90 Series. Continued.



# APPENDIX A

## REFERENCES

---

AMDF	Army Master Data File (Microfiche)
AR 710-2	Supply Policy Below the Wholesale Level as Contained in Unit Supply UPDATE
AR 725-50	Requisitioning, Receipt and Issuing System in UPDATE
DA PAM 25-30	Consolidated Index of Army Publications (Microfiche)
DA PAM 710-2-1	Using Unit Supply System Manual Procedures as Contained in Unit Supply UPDATE
SB 11-131-2	Vehicular Radio Sets and Authorized Installations (SINCGARS)
TM 11-5820-890-10-1	Operator's Manual (ICOM Radio Sets)
TM 11-5820-890-10-3	Operator's Manual (Non-ICOM Radio Sets)
TM 11-5820-890-20-1	Unit Maintenance Manual (ICOM Radio Sets, Vol. 1)
TM 11-5820-890-20-2	Unit Maintenance Manual (ICOM Radio Sets, Vol. 2)
TM 11-5820-890-20-3	Unit Maintenance Manual Handbook (ICOM Radio Sets)
TM 11-5820-890-20-4	Unit Maintenance Manual (Non-ICOM Radio Sets)
TM 11-5820-890-20P	Repair Parts and Special Tools List

By Order of the Secretary of the Army:

Official:

  
JOEL B. HUDSON  
*Administrative Assistant to the  
Secretary of the Army*  
9916737

ERIC K. SHINSEKI  
*General, United States Army  
Chief of Staff*

DISTRIBUTION:

To be distributed in accordance with the initial distribution number (IDN) 360455 requirements for TB 11-5820-890-20-102.

# SOMETHING WRONG WITH THIS PUBLICATION



THEN ... JOT DOWN THE INFO ABOUT IT ON THIS FORM. CAREFULLY TEAR IT OUT. FOLD IT AND DROP IT IN THE MAIL.

FROM: (PRINT YOUR UNIT'S COMPLETE ADDRESS)

Commander  
Stateside Army Depot  
ATTN: AMSTA-US  
Stateside, NJ 07703-5007

DATE SENT

10 July 1995

PUBLICATION NUMBER

TM 11-5840-340-12

PUBLICATION DATE

23 Jan 74

PUBLICATION TITLE

Radar Set AN/PRC-76

BE EXACT PIN-POINT WHERE IT IS

IN THIS SPACE TELL WHAT IS WRONG AND WHAT SHOULD BE DONE ABOUT IT:

PAGE NO	PARA-GRAPH	FIGURE NO	TABLE NO
2-25	2-28		
3-10	3-3		3-1
5-6	5-8		
		FO-3	

Recommend that the installation antenna alignment procedure be changed throughout to specify a 20 IFF antenna lag rather than 10

REASON: Experience has shown that with only a 10 lag, the antenna servo system is too sensitive to gusting in excess of 25 knots, and has a tendency to rapidly accelerate and decelerate as it hunts, causing strain to the drive train. Hunting is minimized by adjusting the lag to 20 without degradation of operation.

Item 5, Functional column. Change  2 dB" to  3 dB".

REASON: The adjustment procedure for the TRANS POWER FAULT indicator call for a 3 dB (500 watts) adjustment to light the TRANS POWER FAULT indicator.

Add new step f.1 to read,  Replace cover plate removed in step d above."

REASON: To replace the cover plate.

ZONE C 3. On J1-2, change  +24 VDC" to  +5 VDC".

REASON: This is the output line of the 5 VDC power supply. +24 VDC is the input voltage.

PRINTED NAME, GRADE OR TITLE AND TELEPHONE NUMBER

SSG I. M. DeSpirito 999-1779

SIGN HERE

TEAR ALONG DOTTED LINE

# SOMETHING WRONG WITH THIS PUBLICATION



THEN ... JOT DOWN THE INFO ABOUT IT ON THIS FORM. CAREFULLY TEAR IT OUT. FOLD IT AND DROP IT IN THE MAIL.

--

DATE SENT
-----------

PUBLICATION NUMBER
--------------------

PUBLICATION DATE
------------------

PUBLICATION TITLE
-------------------

BE EXACT PIN-POINT WHERE IT IS

IN THIS SPACE TELL WHAT IS WRONG AND WHAT SHOULD BE DONE ABOUT IT:

PAGE NO	PARA-GRAPH	FIGURE NO	TABLE NO

--

TEAR ALONG DOTTED LINE

PRINTED NAME, GRADE OR TITLE AND TELEPHONE NUMBER
---

SIGN HERE
-----------

FILL IN YOUR  
UNIT'S ADDRESS

FOLD BACK

DEPARTMENT OF THE ARMY



OFFICIAL BUSINESS

PLEASE  
AFFIX  
STAMP  
POSTAGE  
REQUIRED

TEAR ALONG DOTTED LINE

**Commander**  
**U.S. Army Communications-Electronics Command**  
**and Fort Monmouth**  
**ATTN: AMSEL-LC-LEO-D-CS-CFO**  
**Fort Monmouth, New Jersey 07703-5000**



FOLD BACK

# THE METRIC SYSTEM AND EQUIVALENTS

## WEIGHT MEASURE

1 Centimeter = 10 Millimeters = 0.01 Meters = 0.3937 Inches  
 1 Meter = 100 Centimeters = 1000 Millimeters = 39.37 Inches  
 1 Kilometer = 1000 Meters = 0.621 Miles

## WEIGHTS

1 Gram = 0.001 Kilograms = 1000 Milligrams = 0.035 Ounces  
 1 Kilogram = 1000 Grams = 2.2 lb.  
 1 Metric Ton = 1000 Kilograms = 1 Megagram = 1.1 Short Tons

## LIQUID MEASURE

1 Milliliter = 0.001 Liters = 0.0338 Fluid Ounces  
 1 Liter = 1000 Milliliters = 33.82 Fluid Ounces

## SQUARE MEASURE

1 Sq. Centimeter = 100 Sq. Millimeters = 0.155 Sq. Inches  
 1 Sq. Meter = 10,000 Sq. Centimeters = 10.76 Sq. Feet  
 1 Sq. Kilometer = 1,000,000 Sq. Meters = 0.386 Sq. Miles

## CUBIC MEASURE

1 Cu. Centimeter = 1000 Cu. Millimeters = 0.06 Cu. Inches  
 1 Cu. Meter = 1,000,000 Cu. Centimeters = 35.31 Cu. Feet

## TEMPERATURE

$5/9(^{\circ}\text{F} - 32) = ^{\circ}\text{C}$   
 212° Fahrenheit is equivalent to 100° Celsius  
 90° Fahrenheit is equivalent to 32.2° Celsius  
 32° Fahrenheit is equivalent to 0° Celsius  
 $9/5^{\circ}\text{C} + 32 = ^{\circ}\text{F}$

## APPROXIMATE CONVERSION FACTORS

TO CHANGE	TO	MULTIPLY BY
Inches	Centimeters	2.540
Feet	Meters	0.305
Yards	Meters	0.914
Miles	Kilometers	1.609
Square Inches	Square Centimeters	6.451
Square Feet	Square Meters	0.093
Square Yards	Square Meters	0.836
Square Miles	Square Kilometers	2.590
Acres	Square Hectometers	0.405
Cubic Feet	Cubic Meters	0.028
Cubic Yards	Cubic Meters	0.765
Fluid Ounces	Milliliters	29.573
its	Liters	0.473
arts	Liters	0.946
allons	Liters	3.785
Ounces	Grams	28.349
Pounds	Kilograms	0.454
Short Tons	Metric Tons	0.907
Pound-Feet	Newton-Meters	1.356
Pounds per Square Inch	Kilopascals	6.895
Miles per Gallon	Kilometers per Liter	0.425
Miles per Hour	Kilometers per Hour	1.609

TO CHANGE	TO	MULTIPLY BY
Centimeters	Inches	0.394
Meters	Feet	3.280
Meters	Yards	1.094
Kilometers	Miles	0.621
Square Centimeters	Square Inches	0.155
Square Meters	Square Feet	10.764
Square Meters	Square Yards	1.196
Square Kilometers	Square Miles	0.386
Square Hectometers	Acres	2.471
Cubic Meters	Cubic Feet	35.315
Cubic Meters	Cubic Yards	1.308
Milliliters	Fluid Ounces	0.034
Liters	Pints	2.113
Liters	Quarts	1.057
ers	Gallons	0.264
ms	Ounces	0.035
ograms	Pounds	2.205
Metric Tons	Short Tons	1.102
Newton-Meters	Pounds-Feet	0.738
Kilopascals	Pounds per Square Inch	0.145
ometers per Liter	Miles per Gallon	2.354
ometers per Hour	Miles per Hour	0.621



**PIN: 075954-000**